

PARABODY INC.

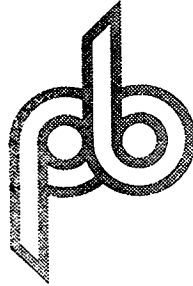

**PROSYSTEM PEC DEC OPTION
894**

**ASSEMBLY
INSTRUCTIONS**

TOOLS REQUIRED FOR ASSEMBLY

- 3/4 INCH SOCKET
- 9/16 INCH SOCKET
- ADJUSTABLE WRENCH
- RUBBER Mallet or HAMMER

REVISION: A

If you experience any problem with the assembly of this product, please contact your dealer or your PARABODY Customer Service Representative at:

1-800-328-9714

894 PROSYSTEM PEC DEC OPTION PARTS LIST

SORT AND COUNT ALL PARTS BEFORE BEGINNING ASSEMBLY

HARDWARE:

ITEM	NAME/DESCRIPTION	QTY
1.	1/2 X 3-1/2 IN. BOLT	2
2.	3/8 X 3-1/4 IN. BOLT	1
3.	3/8 X 3 IN. BOLT	1
4.	3/8 X 2 IN. BOLT	2
5.	3/8 X 1-3/4 IN. BOLT	2
6.	5/16 X 1 IN. BOLT	2
7.	1/2 IN. WASHER	4
8.	3/8 IN. WASHER	1
9.	5/16 IN. WASHER	4
10.	1/2 IN. LOCK WASHER	2
11.	3/8 IN. LOCK WASHER	6
12.	5/16 IN. LOCK WASHER	2
13.	1/2 IN. NUT	2
14.	3/8 IN. NUT	4
15.	5/16 IN. NUT	2
16.	1/4 IN. QUICK LINK	1
17.	CABLE RETAINING CLIP	3
18.	STAR LOCK COLLAR	2
19.	FLANGE BEARING	4
20.	2 IN. SQ. END CAP	9
21.	PLASTIC STOPS	2

NOTE: BOLT LENGTH IS MEASURED FROM THE UNDERSIDE OF THE HEAD OF THE BOLT.

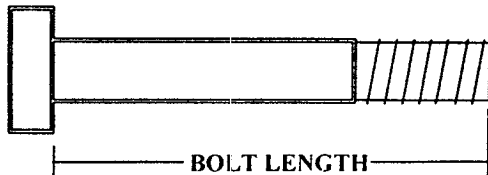

BOLT LENGTH RULER:

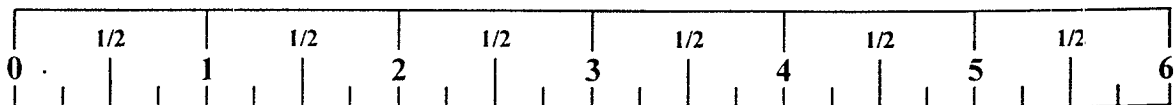

894 PROSYSTEM PEC DEC OPTION PARTS LIST

SORT AND COUNT ALL PARTS BEFORE BEGINNING ASSEMBLY

WELDMENTS/PARTS:

<u>ITEM</u>	<u>NAME/DESCRIPTION</u>	<u>QTY</u>
1.	BEARING HOUSING(6259703).....	1
2.	PULLEY MOUNT SUPPORT(6258603).....	1
3.	PEC-DEC ARM RIGHT(6187903).....	1
4.	PEC-DEC ARM LEFT(6187603).....	1
5.	LOWER PULLEY SUPPORT(6260403).....	1
6.	PULLEY LOOP BRACKET(6260303).....	1
7.	BACK PAD(6457501).....	1
8.	4 X 12 ROLLER PAD(6176201).....	2
9.	SECONDARY SWAP-OUT CABLE(6259901).....	1
10.	LOOP CABLE(6259801).....	1
11.	4-1/2 O.D. X 1 IN. BUSHING PULLEY(3116101).....	4

894 PROSYSTEM PEC DEC OPTION ASSEMBLY INSTRUCTIONS

1. Remove the **SECONDARY CABLE** by disassembling the **CABLE** from its **MAIN UPRIGHT CONNECTION POINT**, and pull **CABLE** out from the **LOW PULLEY STATION**. (**NOTE: REMOVE LOW PULLEY FOR EASE OF REMOVAL**)
2. Insert four (4) 2 IN. SQ. END CAPS into all open ends of the **BEARING HOUSING**.
3. Insert one (1) 2 IN. SQ. END CAP into the end of the **PULLEY MOUNT SUPPORT**.
4. **SECURELY** assemble both the **BEARING HOUSING** and the **PULLEY MOUNT SUPPORT** to the **MAIN UPRIGHT** of the **BODYSMITH PROSYSTEM**, using two (2) 1/2 X 3-1/2 IN. BOLTS, four (4) 1/2 IN. WASHERS, two (2) 1/2 IN. LOCK WASHERS, and two (2) 1/2 IN. NUTS.

NOTE: THE CONNECTOR PLATES ON THE BEARING HOUSING AND THE PULLEY MOUNT SUPPORT HAVE OVAL HOLES. MOVE THE BEARING HOUSING DOWN AND THE PULLEY MOUNT SUPPORT UP AS FAR AS POSSIBLE. SEE DRAWING

5. **CAREFULLY** insert four (4) **FLANGE BEARINGS** into the **TOP** and **BOTTOM** sides of the **BUSHINGS** of the **BEARING HOUSING** on both sides. (**CAUTION: DO NOT OVER TAP THESE BEARINGS INTO PLACE, WHICH CAN CAUSE DEFORMATION TO THE BEARINGS, MAKING THEM UNUSABLE**)
6. Insert four (4) 2 IN. SQ. END CAPS into **BOTH ENDS** of the **LEFT** and **RIGHT PEC-DEC ARMS**.
7. Insert the **LEFT** and **RIGHT PEC-DEC ARMS** through the **FLANGE BEARINGS** in the **BEARING HOUSING** on their respective sides, and secure them in place with two (2) **STAR LOCK COLLARS**.
8. Attach two (2) **PLASTIC STOPS** to the **CAM STOP** on the **BEARING HOUSING**, approximately where shown, in order to give the **PEC-DEC ARM CAMS** full contact when the **PEC-DEC ARMS** are in their resting position.
9. Slide two (2) 4 X 12 **ROLLER PADS** onto the **LEFT** and **RIGHT PEC-DEC ARMS**, until the **ROLLER PAD** is **FLUSH** with the bottom of the **ARMS**. (**NOTE: IF A LUBRICANT IS REQUIRED, RUBBING ALCOHOL THOROUGHLY COATING THE INSIDE OF THE ROLLER IS THE BEST MATERIAL TO USE. ALSO, ROTATING THE PAD WHILE PUSHING UP WILL HELP TO EASE ASSEMBLY**)
10. **LOOSELY** assemble two (2) 4-1/2 O.D. X 1 IN. **BUSHING PULLEYS** and two (2) **CABLE RETAINING CLIPS** to the **PULLEY MOUNT SUPPORT**, using two (2) 3/8 X 2 IN. BOLTS, two 3/8 IN. LOCK WASHERS, and two (2) 3/8 IN. NUTS. (**NOTE: THIS CONNECTION WILL BE TIGHTENED AFTER THE CABLE HAS BEEN ROUTED**)
11. **LOOSELY** assemble the **BACK PAD** to the **TOP HOLE** of the **MAIN UPRIGHT**, using one (1) 3/8 X 3 IN. BOLT, one (1) 3/8 IN. LOCK WASHER, and one (1) 3/8 IN. WASHER
12. Using one (1) 3/8 X 3-1/4 IN. BOLT, and one (1) 3/8 IN. LOCK WASHER. **SECURELY** assemble the **LOWER PULLEY SUPPORT** through the **BOTTOM HOLE** of the **MAIN UPRIGHT** and into the **BACK PAD**. (**NOTE: MAKE SURE THAT THE BASE PLATE OF THE LOWER PULLEY SUPPORT IS FLUSH WITH THE SIDES OF THE MAIN UPRIGHT. SEE DRAWING**)
13. **TIGHTEN** the **BOLT** in **STEP 11**.

894 PROSYSTEM PEC DEC OPTION ASSEMBLY INSTRUCTIONS

14. **SECURELY** assemble one (1) 4-1/2 O.D. X 1 IN. BUSHING PULLEY to the **LOWER PULLEY SUPPORT**, using one (1) 3/8 X 1-3/4 IN. BOLT, one (1) 3/8 LOCK WASHER, and one (1) 3/8 IN. NUT.

15. **LOOSELY** assemble one (1) 4-1/2 O.D. X 1 IN. BUSHING PULLEY and one (1) **CABLE RETAINING CLIP** to the **PULLEY LOOP BRACKET**, using one (1) 3/8 X 1-3/4 IN. BOLT, one (1) 3/8 IN. LOCK WASHER, and one (1) 3/8 IN. NUT. (SEE **DETAIL B**)

NOTE: BEFORE PROCEEDING WITH CABLE INSTALLATION, UNRAVEL CABLE, AND REMOVE AS MUCH SPIRALING AS POSSIBLE.

16. To install **LOOP CABLE (PB2598-1)**, start by **SECURELY** assembling both ends of the **LOOP CABLE** to the **CAMS** of the **LEFT** and **RIGHT PEC-DEC ARMS**, using two (2) 5/16 X 1 IN. BOLTS, four (4) 5/16 IN. WASHERS, two (2) 5/16 IN. LOCK WASHERS, and two (2) 5/16 IN. NUTS. (**NOTE: MAKE SURE THE CABLE ENDS REST FLAT AGAINST THE INSIDE OF THE CAMS**) (SEE **DETAIL C**)

- Drape both sides of the **CABLE** over the **PULLEYS** on the **PULLEY MOUNT SUPPORT**. Position **CABLE RETAINING CLIPS** on the **PULLEY MOUNT SUPPORT** in a vertical position over the **PULLEY** and **CABLE**, after the **LOOP CABLE** has been routed. Tighten the **PULLEY CONNECTION** completely.

- Place the **PULLEY** on the **PULLEY LOOP BRACKET** over the **LOOP** of the **CABLE** created from the above step. Position the **CABLE RETAINING CLIP** in a vertical position under the **CABLE** and **PULLEY**. Tighten **PULLEY CONNECTION** completely. (**NOTE: MAKE SURE THAT THE CABLE IS IN THE GROOVE OF THE PULLEY BEFORE TIGHTENING**)

- See **CABLE ROUTING DIAGRAM** for help in completing **STEP 16**.

17. To install **SECONDARY SWAP-OUT CABLE (PB2599-1)**, start by inserting the end of the **CABLE**, **WITHOUT** the **WHITE BALL** under the **FRONT PULLEY** in the **LOW ROW PULLEY HOUSING** on the **MAIN UPRIGHT**. (**REMOVE PULLEY FOR EASE OF INSTALLATION**)

- Push the **CABLE** under the **FRONT PULLEY** and through the **HOLE** of the **MAIN UPRIGHT** to the **PULLEY** on the **UPRIGHT BRACE** of the **MAIN UPRIGHT**. Pull **CABLE** until the **WHITE BALL** stops against the **FRONT PULLEY** and the **LOW ROW PULLEY HOUSING**.

- Pull the **CABLE** around the **BRACE PULLEY** and up to the **SECOND PULLEY** on the **PULLEY BLOCK SYSTEM**. (**NOTE: THE CABLE MUST BE ROUTED AROUND THE SECOND PULLEY FROM THE REAR TO THE FRONT**)

- Pull **CABLE** around the **SECOND PULLEY** of the **PULLEY BLOCK SYSTEM** and down to the **PULLEY** on the **LOWER PULLEY SUPPORT**. Pull **CABLE** around underneath the **PULLEY**, and attach it to the **HOLE** of the **PULLEY LOOP BRACKET**, using 1/4 IN. QUICK LINK. (SEE **DETAIL A**)

- See **CABLE ROUTING DIAGRAM** for help in completing **STEP 17**.

18. If assembling the **PEC DEC OPTION** and the **MAIN UNIT** at the same time, return to the **MAIN UNIT ASSEMBLY INSTRUCTIONS**, and continue on with **STEP 25**.

A	NEW RELEASE	2386	DMT	7/94
B	MOVE SERIAL NO.	2486	DLM	11/94

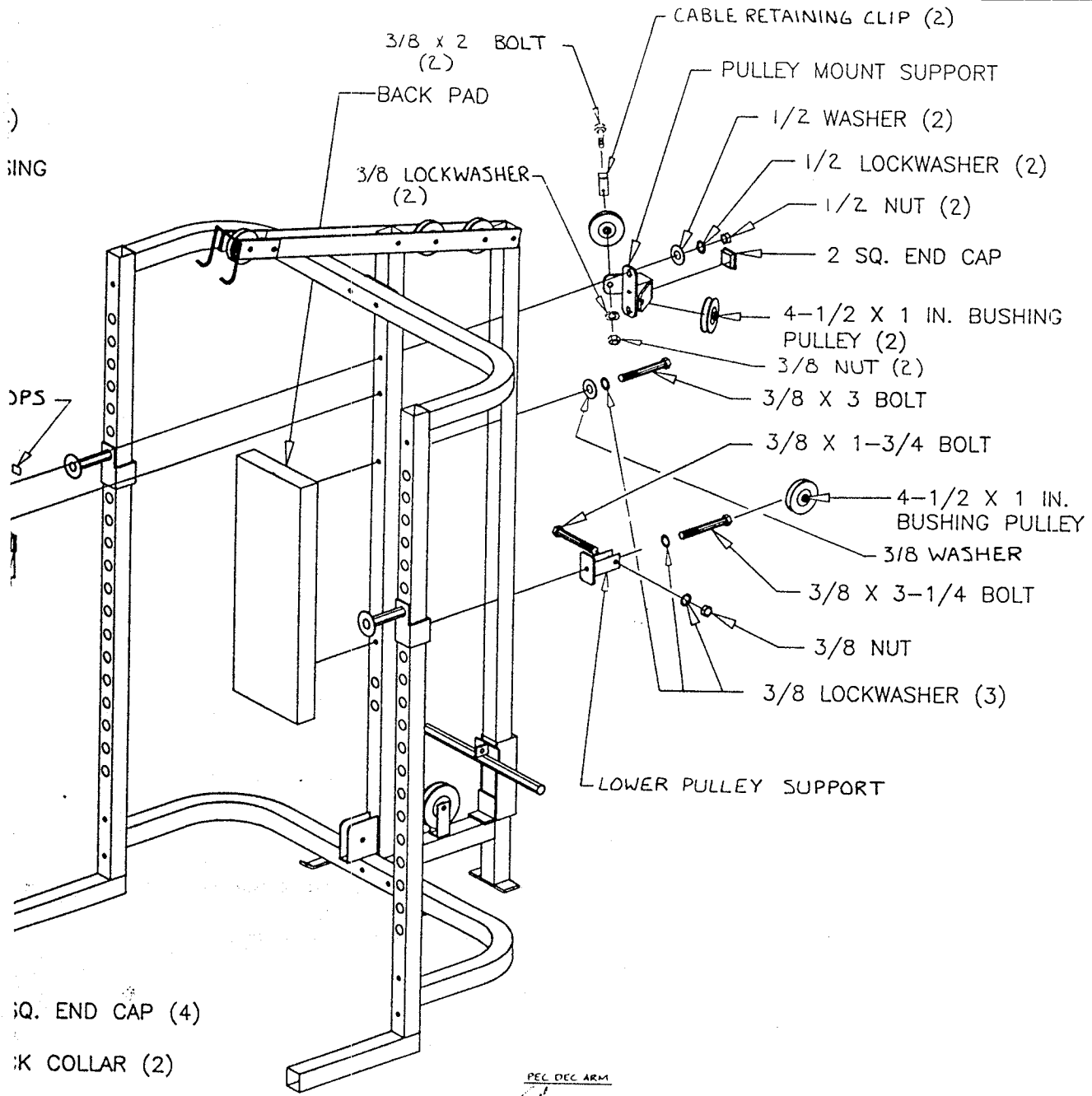

SQ. END CAP (4)
 W/ K COLLAR (2)
 (2)
 BOLT (2)

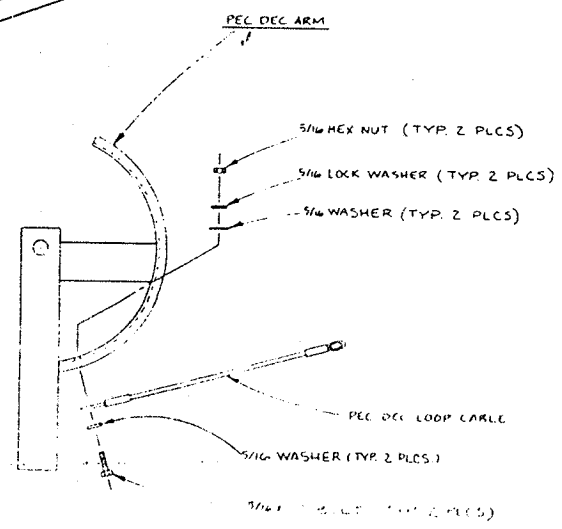

DETAIL "C"

TOLERANCES (EXCEPT AS NOTED)			
DIMENSIONAL			
FINISH	ASSY INST. 894101		
SCALE	NONE	SIZE	DRAWING NO.
QUANTITY	1	SHEET	OF 3 (1)
			63995

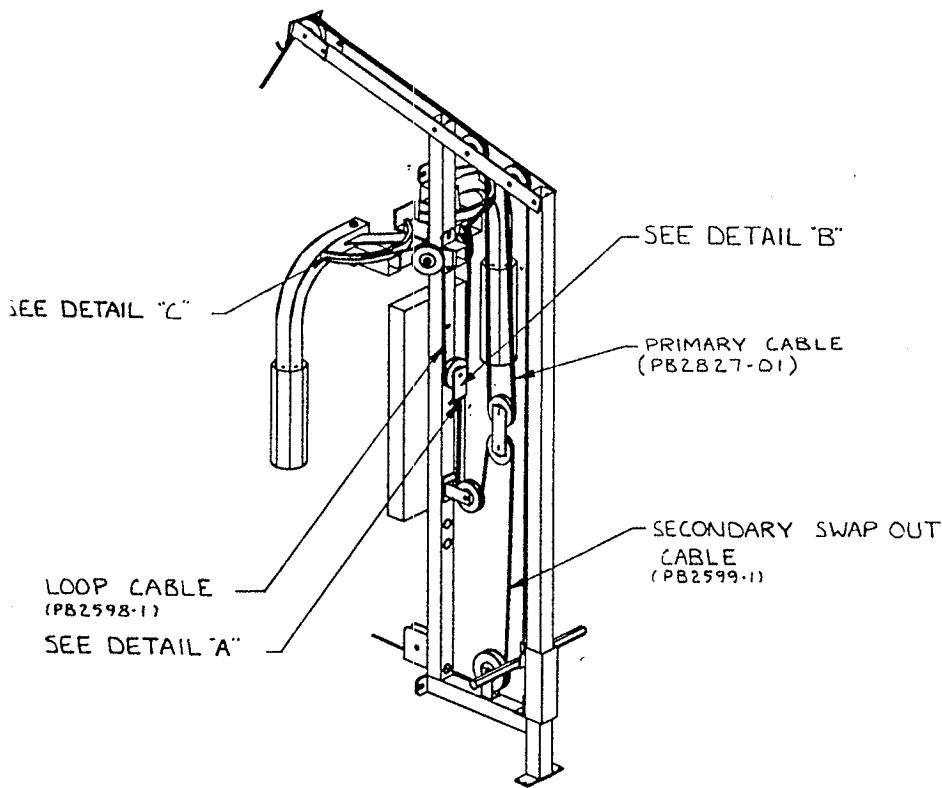

CABLE ROUTING DIAGRAM

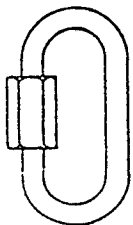

CAUTION!!! - THE QUICK LINK HEX NUT MUST BE FULLY ENGAGED AND TIGHT WITH THE THREADS BEFORE DOING ANY EXERCISE.

DETAIL "A"

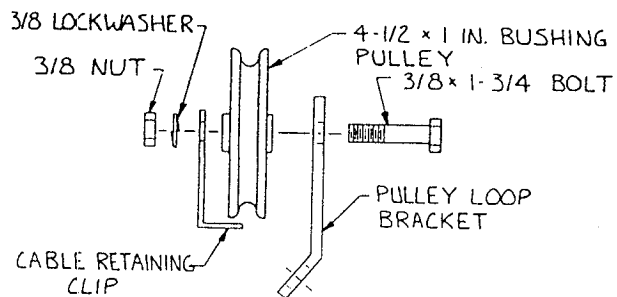

DETAIL "B"

